

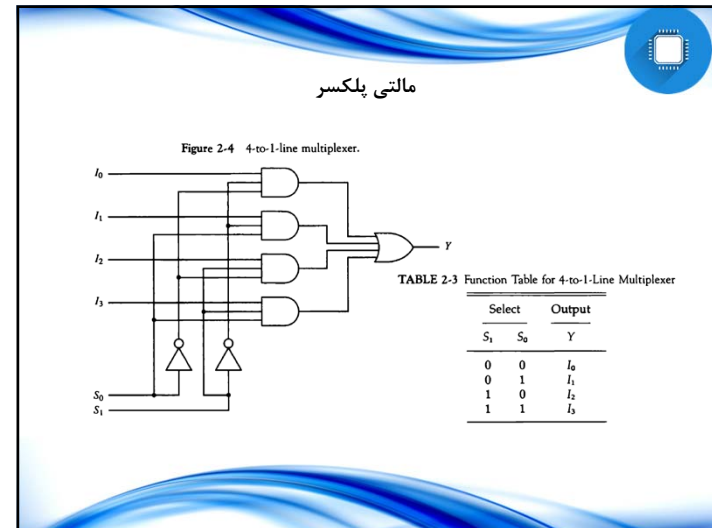

جلسه سوم: یادآوری مباحث از مدار منطقی
از مالتی پلکسر تا انتهای فصل دو



پایاده سازی توابع با مالتی پلکسر

مثال تابع $f(a, b, c) = \sum m(0,1,4,7)$
 را با یک مالتی پلکسر ۴:۱ پایاده سازی کنید.

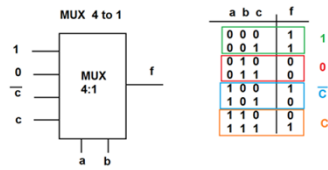

مالتی پلکسر چهار کاناله

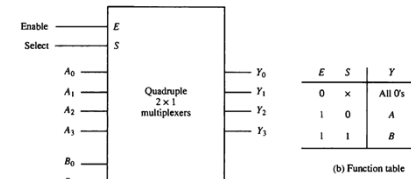

Figure 2-5 Quaduple 2-to-1 line multiplexers.

رجیسترها (ثبات ها)

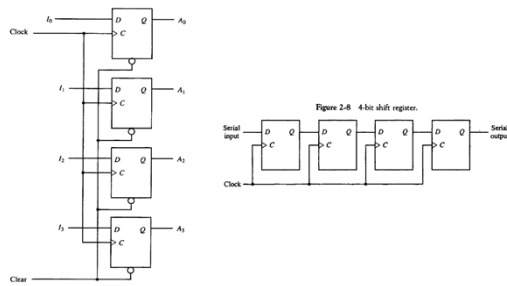
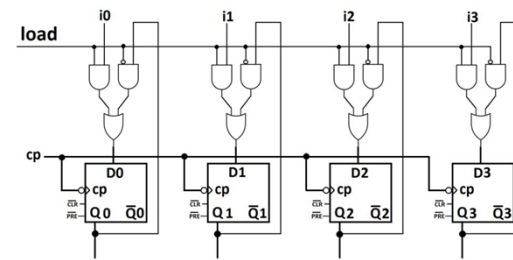
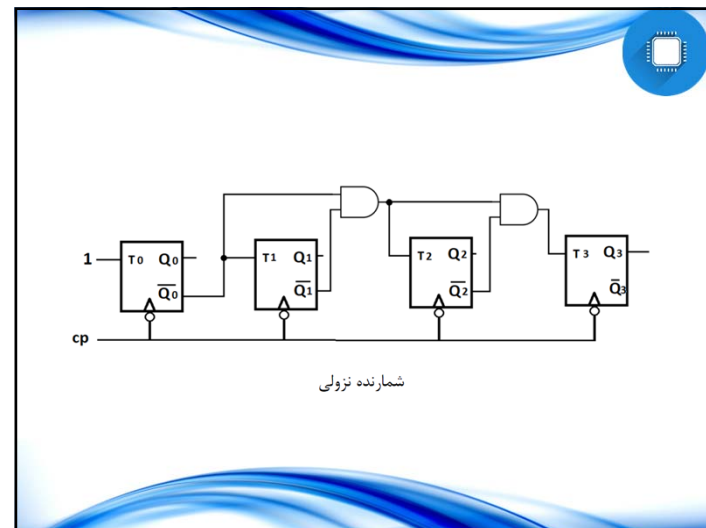
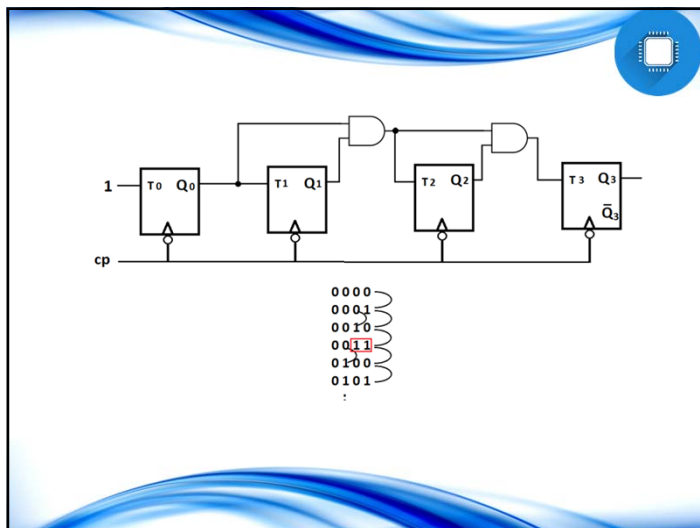
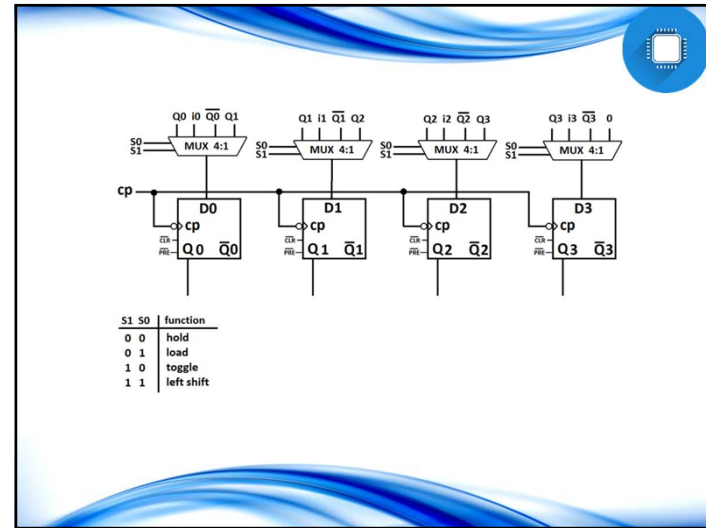
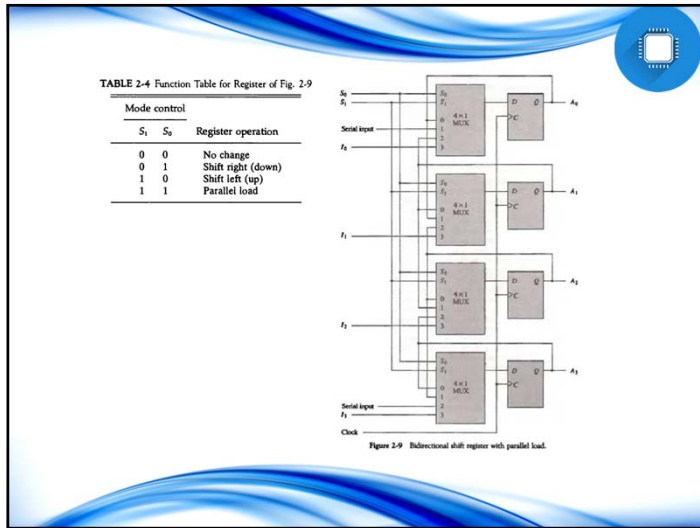
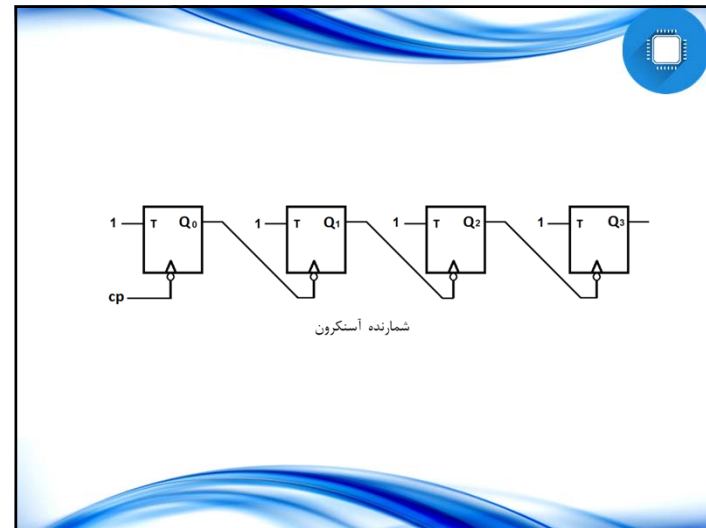
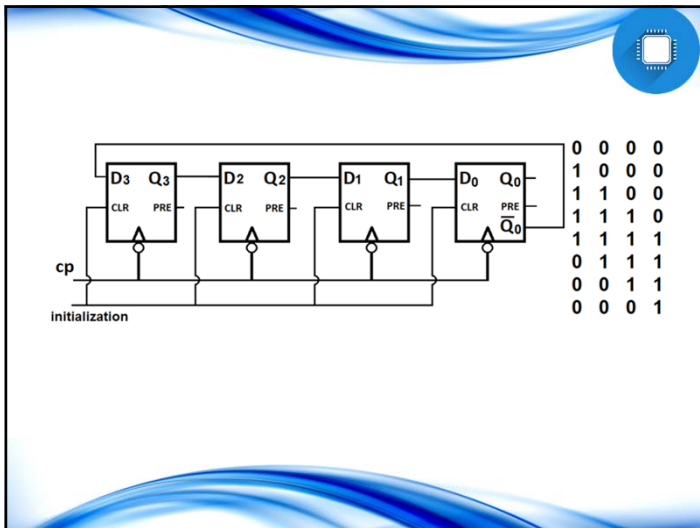
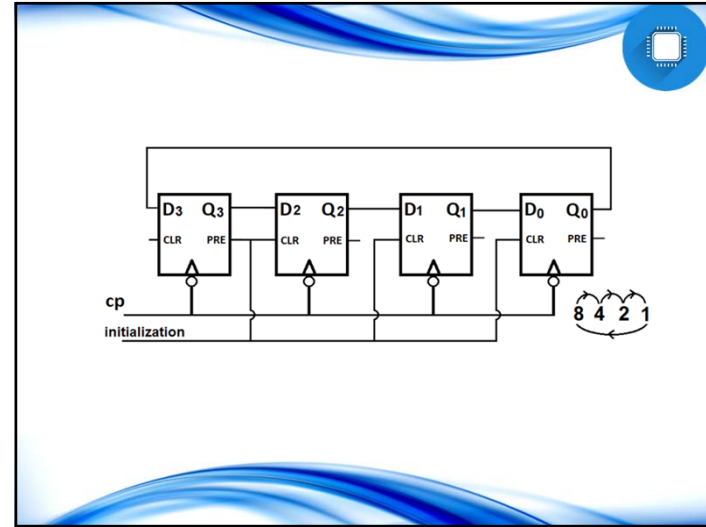
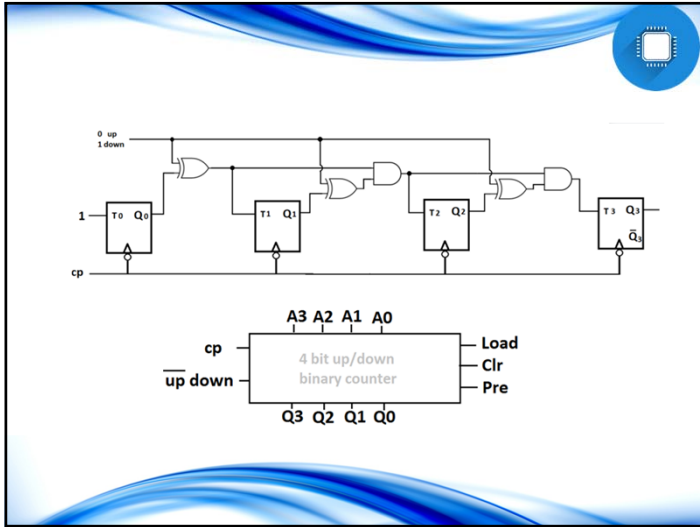

Figure 2-8 4-bit shift register.







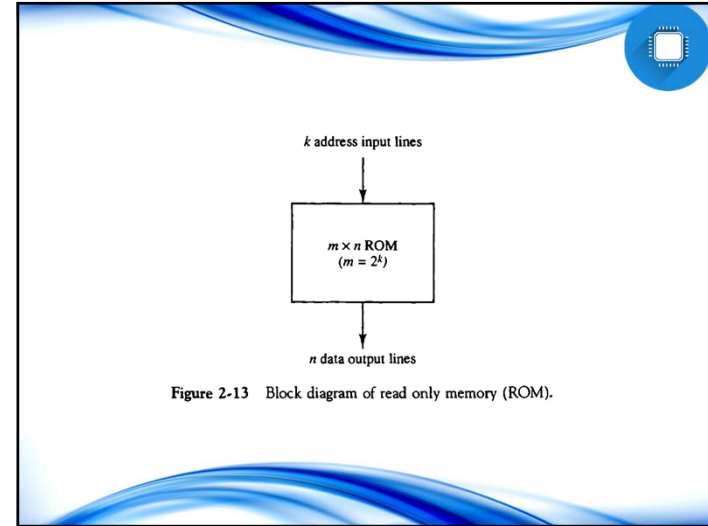
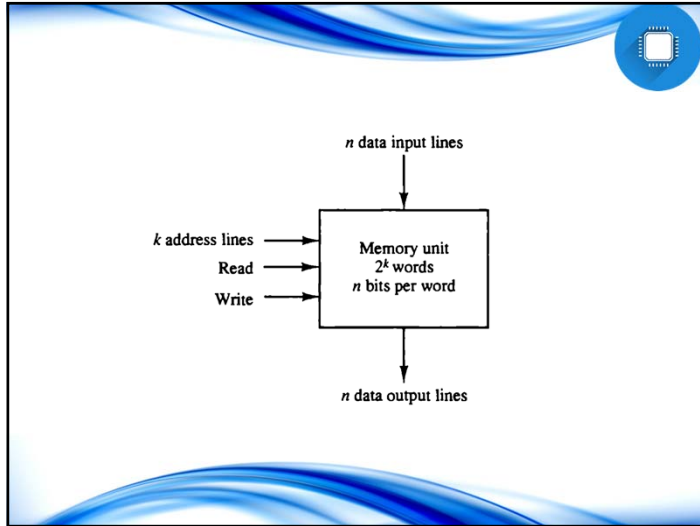

Figure 2-13 Block diagram of read only memory (ROM).

لیست تمرین های مهم فصل دو

- ۳ •
- ۴ •
- ۷ •
- ۱۲ •
- ۱۹ •
- ۲۲ •

